

- NOTES**
- DO NOT SCALE FROM THIS DRAWING
 - ALL DIMENSIONS IN METRES UNLESS OTHERWISE STATED
 - FORWARD MOVEMENTS TRACKED AT A SPEED OF 10mph IN ACCORDANCE WITH HCC TECHNICAL GUIDANCE NOTE TG2

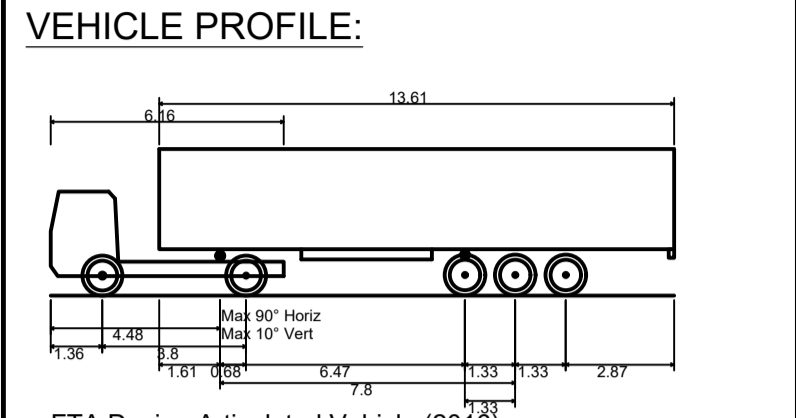

FTA Design Articulated Vehicle (2018)

Overall Length	16.480m
Overall Width	2.550m
Overall Body Height	3.870m
Min Body Ground Clearance	0.515m
Max Track Width	2.470m
Lock to lock time	3.00s
Kerb to Kerb Turning Radius	6.600m

- VEHICLE TRACKING KEY**
- FORWARD MOVEMENTS
- KEY**
- PROPOSED KERB
 - PROPOSED CARRIAGEWAY WIDENING/ NEW CONSTRUCTION
 - PROPOSED WHITE COLOURED ROAD MARKING
 - PROPOSED YELLOW COLOURED ROAD MARKING
 - EXISTING RETAINED ROAD MARKINGS
 - EXISTING HIGHWAY BOUNDARY
 - PROPOSED TACTILE PAVING
 - PROPOSED PEDESTRIAN FENCING

© CROWN COPYRIGHT AND DATABASE RIGHTS 2024
ORDNANCE SURVEY 100019180

SUIT	REV	PURPOSE OF ISSUE AND DESCRIPTION OF AMENDMENTS	DATE	DESIGNER	CAD	CHKD	APPD
S2	P02	AMENDMENTS FOLLOWING PLANNING PRE-APPLICATION FEEDBACK	27.03.2025	RH/JA	RH	JS	GC
S2	P01	FIT FOR INFORMATION	09.10.2024	RH/JA	RH	JS	GC

CLIENT
**HAMPSHIRE COUNTY COUNCIL
UNIVERSAL SERVICES DIRECTORATE
TRANSPORT IMPLEMENTATION**

CONSULTANT
**Hampshire
County Council
Engineering Services**
TIM LAWTON BEng CEng FICE FCIHT - ASSISTANT DIRECTOR OF UNIVERSAL SERVICES

HORIZONTAL SCALE @ A1
1:250
VERTICAL SCALE @ A1
N/A
SHEET NUMBER
1 OF 2
SCHEME
ANDOVER - WESTERN AVENUE
JOB No. C.J009625.01

DRAWING TITLE
**WEST STREET JUNCTION
SWEEP PATH ANALYSIS**
HCC CAD PLOT: 27/03/2025 8:58:40
SUIT REV
S2 P02

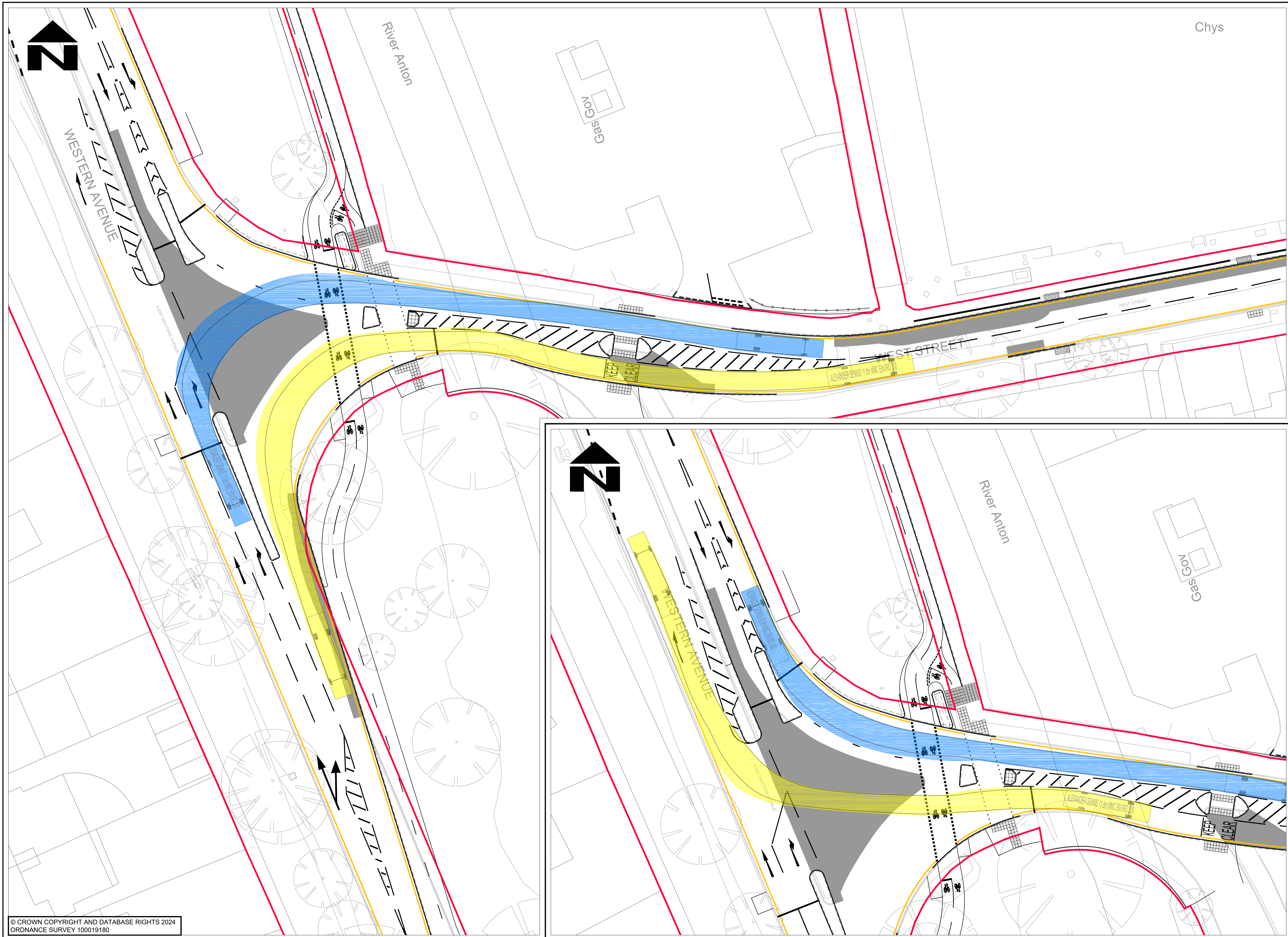

- NOTES**
- DO NOT SCALE FROM THIS DRAWING
 - ALL DIMENSIONS IN METRES UNLESS OTHERWISE STATED
 - FORWARD MOVEMENTS TRACKED AT A SPEED OF 10mph IN ACCORDANCE WITH HCC TECHNICAL GUIDANCE NOTE TG2

VEHICLE PROFILE:

ALEXANDER DENNIS 11.8m MMC ENVIRO 200	
Overall Length	11.810m
Overall Width	2.470m
Overall Body Height	2.866m
Min Body Ground Clearance	0.315m
Track Width	2.300m
Lock to lock time	4.00s
Wall to Wall Turning Radius	11.847m

- VEHICLE TRACKING KEY**
- FORWARD MOVEMENTS
 - REVERSE MOVEMENTS
 - PARKED VEHICLES
- KEY**
- PROPOSED KERB
 - PROPOSED CARRIAGEWAY WIDENING/ NEW CONSTRUCTION
 - PROPOSED WHITE COLOURED ROAD MARKING
 - PROPOSED YELLOW COLOURED ROAD MARKING
 - EXISTING RETAINED ROAD MARKINGS
 - EXISTING HIGHWAY BOUNDARY
 - PROPOSED TACTILE PAVING
 - PROPOSED PEDESTRIAN FENCING

© CROWN COPYRIGHT AND DATABASE RIGHTS 2024
ORDNANCE SURVEY 100019180

SUIT	REV	PURPOSE OF ISSUE AND DESCRIPTION OF AMENDMENTS	DATE	DESIGNER	CAD	CHKD	APPD
S2	P02	AMENDMENTS FOLLOWING PLANNING PRE-APPLICATION FEEDBACK	27.03.2025	RH/JA	RH	JS	GC
S2	P01	FIT FOR INFORMATION	09.10.2024	RH/JA	RH	JS	GC

CLIENT
**HAMPSHIRE COUNTY COUNCIL
UNIVERSAL SERVICES DIRECTORATE
TRANSPORT IMPLEMENTATION**

CONSULTANT
**Hampshire
County Council**
Engineering Services
TIM LAWTON BEng CEng FICE FCIHT - ASSISTANT DIRECTOR OF UNIVERSAL SERVICES

HORIZONTAL SCALE @ A1 1:250	SCHEME ANDOVER - WESTERN AVENUE
VERTICAL SCALE @ A1 N/A	
SHEET NUMBER 2 OF 2	

DRAWING TITLE WEST STREET JUNCTION SWEEP PATH ANALYSIS
STATUS OF DRAWING AT SUITABILITY: RED BACKGROUND = WORK IN PROGRESS, AMBER BACKGROUND = SHARED NON-CONTRACTUAL, GREEN BACKGROUND = EARLY PUBLISH & PUBLISHED CONTRACTUAL
JOB No. C.J009625.01 HCC CAD PLOT: 27/03/2025 9:06:02
SUIT REV S2 P02